

BQXR51

系列防爆软起动器(II B)



适用范围 Application

- 适用于1区、2区危险场所。
- 适用于II A、II B类，温度组别为T1~ T4的爆炸性气体环境。
- Can be used in hazardous areas: Zone 1 and Zone 2.
- Can be used in explosive gas atmospheres of Category IIA and 、II B where the temperature classification is T1 ~ T4.

型号含义 Model implication

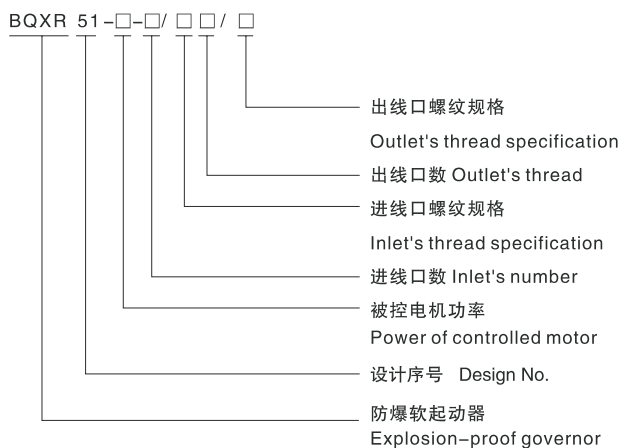

技术参数 Technical parameters

- | | |
|-------------------------------------|--|
| ■ 执行标准：GB 3836.1、GB 3836.2、IEC60079 | ■ Implementing the standard : GB 3836.1、GB 3836.2、IEC60079 |
| ■ 额定电压：AC 380V/220V | ■ Rated voltage: AC380V/220V |
| ■ 防爆标志：Exd II BT4 | ■ Explosion-proof mark: Exd II BT4 |
| ■ 防护等级：IP54 | ■ Protection grade: IP54 |
| ■ 防腐等级：Wf1 | ■ Corrosion-proof grade: Wf1 |

BQXR51

Type explosion-proof soft starter (II B)

产品型号 Type	电机功率(kW) Motor power	额定电流(A) Rated current	进线口螺纹 (G") Inlet thread	电缆外径(φ,mm) Cable's outside diameter
BQXR51-7.5	7.5	6~18	1 1/4	14~25
BQXR51-15	15	10~30	1 1/2	17~28
BQXR51-22	22	22~45		
BQXR51-30	30	29~60	2	25~38
BQXR51-37	37	28~75		
BQXR51-45	45	60~90	2 1/2	32~45
BQXR51-55	55	70~110		
BQXR51-75	75	87.5~145	3	35~55
BQXR51-90	90	105~175		

产品特点 Features

- 产品外壳为钢板焊接或铸铝合金壳体，表面高压静电喷塑；
- 内装ABB或施耐德等公司生产的固态软起动器，防爆软起动器采用逐步升压的方法，实现平滑起动，5KW以上的防爆软起动器设有半导体制冷装置，并具有测温装置，保持机器恒温；
- 可根据负载特性选用常规起动和重载起动，起动参数可自行设定；
- 钢管或电缆布线。
- The shell is made of diecasted Al-alloy or welded of steel plates.
- Inside will be installed ABB or schneider's sold soft starter, which increase voltage step by step to flatly start.
- It shall the starting mode from normal type and heavy-loaded type according to load characteristics, starting parameter can be self-setted.
- Conduit wiring or cable wiring.

BQXR51

系列防爆软起动器(II B)

外形及安装举例 Outline and mounting example

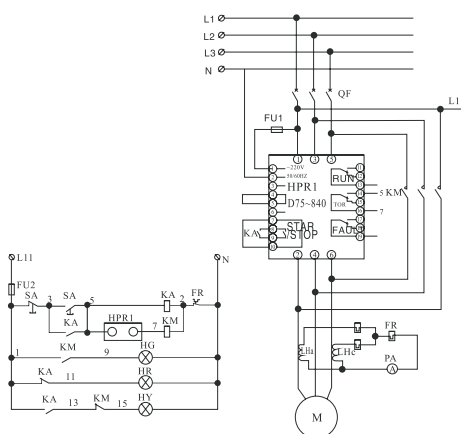
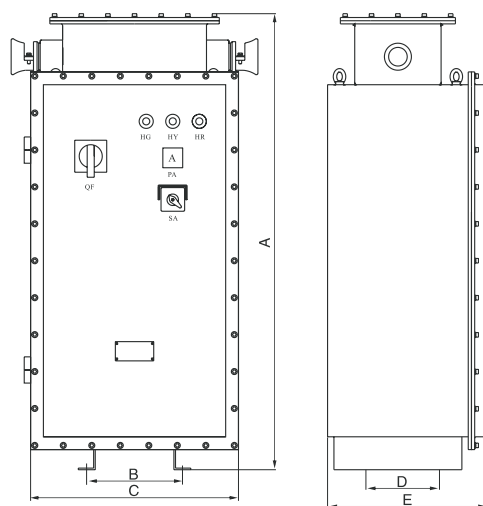

BQXR-37~90kW
电气原理图 Electrical principle chart

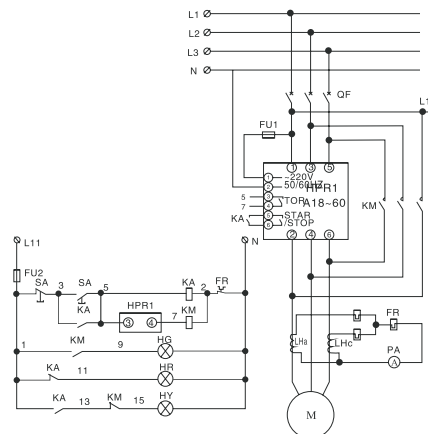

BQXR-7.5~30kW
电气原理图 Electrical principle chart

型号 Type	A	B	C	D	E
BQXR-7.5-55	1200	350	550	220	400
BQXR-7.5-95	1420	390	650	300	500