



标准规格

缸径(mm)		6	10	16	20	25	32
使用流体		空气					
动作方式		双作用 单作用: 弹簧压回/弹簧压出					
最高使用压力		0.7MPa					
最低使用压力MPa	双作用	单杆	0.12	0.06	0.05		
		双杆、杆不回转气缓冲 杆不回转双杆	0.15	0.10	0.08		
	单作用	标准	0.20	0.13	0.11		
		杆不回转	0.23	0.15	0.13	0.16	
环境和流体温度		带磁性开关: -10~60°C, 无磁性开关: -10~70°C					
缓冲		两端橡胶缓冲					
使用活塞速度		50~500mm/s					
行程公差(mm)		+1.0 0					
*给油		不需要					
安装形式		自由(多面安装)					
活塞杆不回转精度		±0.8°			±0.5°		
接管口径		M5×0.8					1/8

*如给油, 请用透平1号油ISOVG32

型号表示方法

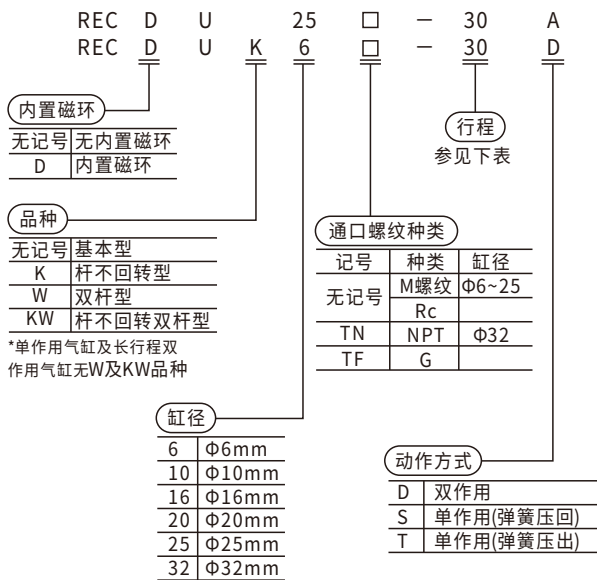

符号

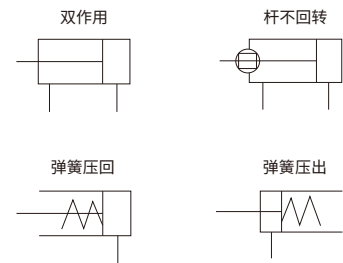

行程

缸径(mm)	标准行程(mm)		长行程(双作用)
	双作用	单作用	
6	5,10,15,20,25,30	5,10,15	40
10			50
16			60
20			60,70
25	5,10,15,20,25,30,40,50		80,90
32			100

*磁性开关规格及特性可参阅磁性开关系列, 导线长度表示记号: 无记号-0.5m, L-3m, Z-5m例: M9N, M9NL.

适应性的安装/长方体气缸

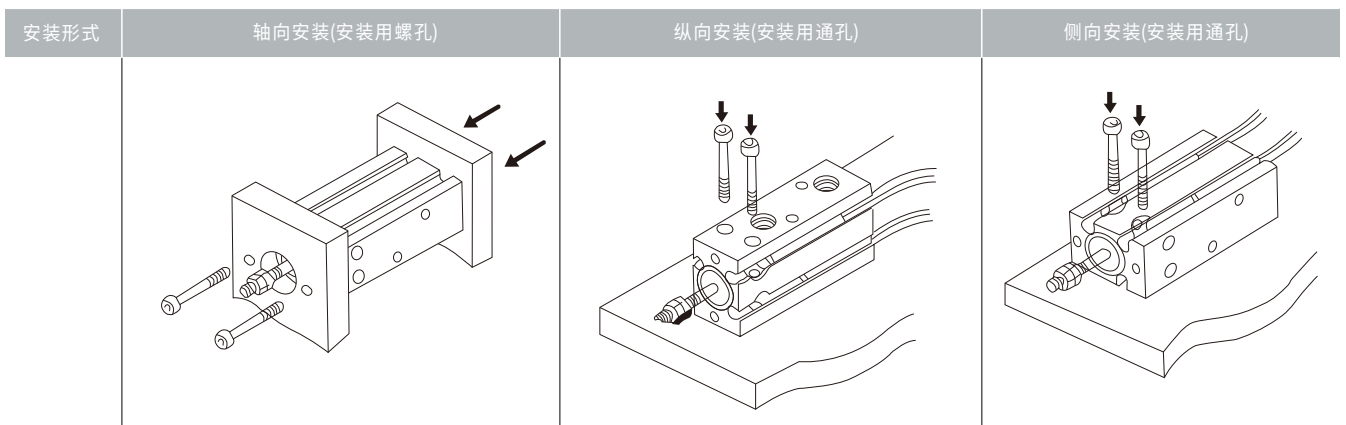

外形尺寸图(毫米)

基本型, 内置磁环型(双作用、单作用弹簧压回/压出)

Φ6, Φ10

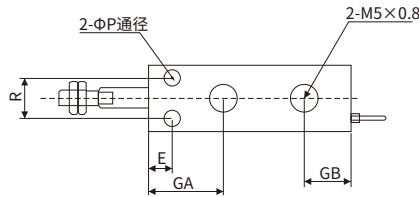

Φ16~Φ25

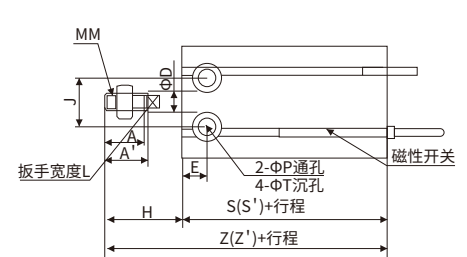
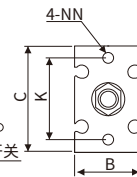
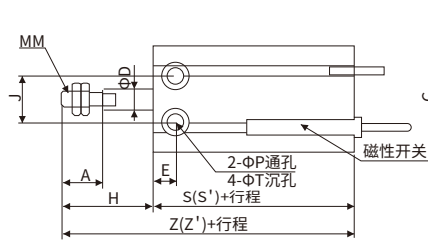
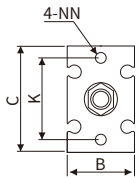
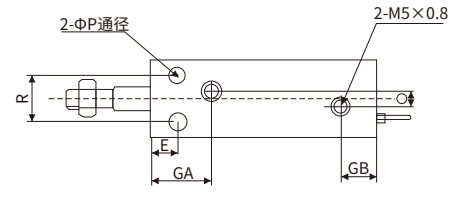

Φ32

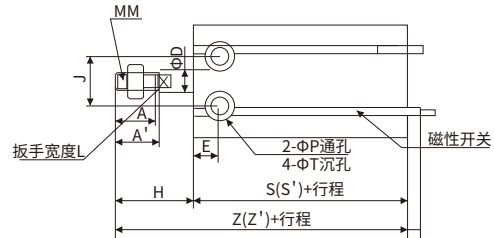
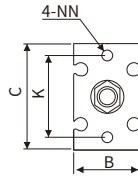
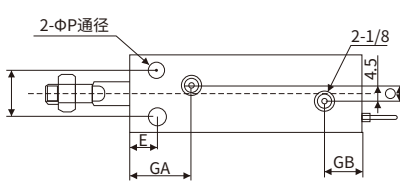

共同尺寸表

型号	A	A'	B	C	ΦD	E	GA	GB	J	K	L	MM	NN	ΦP	Q	R	ΦT
REC□U6	7	—	13	22	3	7	15	10	10	17	—	M3×0.5	M3×0.5深5	3.2	—	7	6深4.8
REC□U10	10	—	15	24	4	7	16.5	10	11	18	—	M4×0.7	M3×0.5深5	3.2	—	9	6深5
REC□U16	11	12.5	20	32	6	7	16.5	11.5	14	25	5	M5×0.8	M4×0.7深	4.5	4	12	7.6深6.5
REC□U20	12	14	26	40	8	9	19	12.5	16	30	6	M6×1.0	M5×0.8深8	5.5	9	16	9.3深8
REC□U25	15.5	18	32	50	10	10	21.5	13	20	38	8	M8×1.25	M5×0.8深8	5.5	9	20	9.3深9
REC□U32	19.5	22	40	62	12	11	23	12.5	24	48	10	M10×1.25	M6×1.0深9	6.6	13.5	24	11深11.5

双作用尺寸表

单作用(弹簧压回)尺寸表

型号	H	基本型		内置磁环型			型号	H	基本型						内置磁环型						
		S	Z	W	S'	Z'			S	Z			W	S'			Z'				
										5st	10st	15st		5st	10st	15st	5st	10st	15st	5st	10st
REC□U6-□D	13	33	46	2.5	33	46	REC□U6-□S	13	38	43	48	51	56	61	2.5	38	43	48	51	56	61
REC□U10-□D	16	36	52	1	36	52	REC□U10-□S	16	41	46	56	57	62	72	1	41	46	56	57	62	72
REC□U16-□D	16	30	46	0	40	56	REC□U16-□S	16	35	40	50	51	56	66	0	45	50	60	61	66	76
REC□U20-□D	19	36	55	1	46	65	REC□U20-□S	19	41	46	56	60	65	75	1	51	56	66	70	75	85
REC□U25-□D	23	40	63	-1	50	73	REC□U25-□S	23	45	50	60	68	73	83	-1	55	60	70	78	83	93
REC□U32-□D	27	42	69	-4	52	79	REC□U32-□S	27	47	52	62	74	79	89	-4	57	62	72	84	89	99

单作用(弹簧压出)尺寸表

*St+行程

型号	H			基本型						内置磁环型						
	5st	10st	15st	S			Z			W	S'			Z'		
				5st	10st	15st	5st	10st	15st		5st	10st	15st	5st	10st	15st
REC□U6-□T	18	23	28	38	43	48	56	66	76	2.5	38	43	48	56	66	76
REC□U10-□T	21	26	31	41	46	56	62	72	87	1	41	46	56	62	72	87
REC□U16-□T	21	26	31	45	50	60	66	76	91	0	45	50	60	66	76	91
REC□U20-□T	24	29	34	41	46	56	65	75	90	1	51	56	66	75	85	100
REC□U25-□T	28	33	38	45	50	60	73	83	98	-1	55	60	70	83	93	108
REC□U32-□T	32	37	42	47	52	62	79	89	104	-4	57	62	72	89	99	114

杆不回转型, 内置磁环型(双作用、单作用弹簧压回/压出)

φ6, φ10

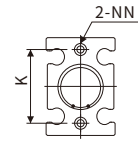
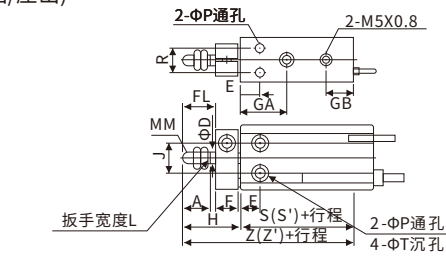
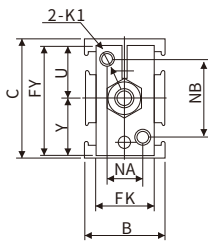

φ16~φ25

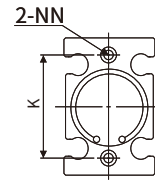
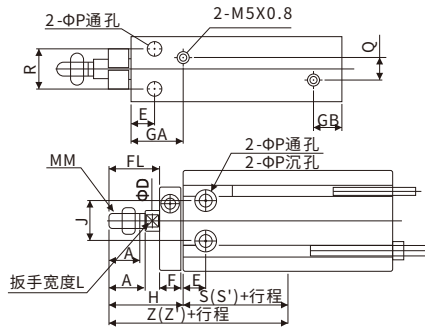
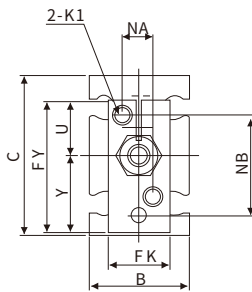

φ32

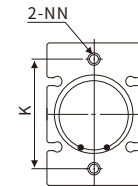
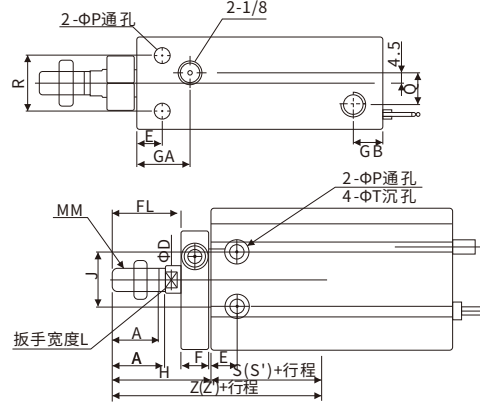
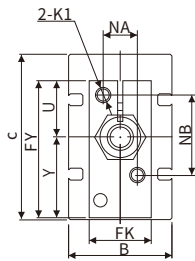

共同尺寸表

型号	A	A'	B	C	φD	E	F	FL	FK	FY	GA	GB	H	J	K	L	MM	NA	NB	NN	φP	Q	R	φT	U	Y	K1
REC□UK6	7	—	13	22	3	7	8	9	11	20.5	15	10	18	10	17	—	M3×0.5	6	14	M3×0.5深5	3.4	—	7	6深4.8	10	10.5	M3
REC□UK10	10	—	15	24	4	7	8	12	12	22	16.5	10	21	11	18	—	M4×0.7	7	15	M3×0.5深5	3.4	—	9	6深5	10.5	11.5	M3
REC□UK16	11	12.5	20	32	6	7	8	17	13	28	16.5	11.5	26	14	25	5	M5×0.8	6	18	M4×0.7深6	4.5	4	12	7.6深6.5	12.5	15.5	M4
REC□UK20	12	14	26	40	8	9	8	20	16	33	19	12.5	29	16	30	6	M6×1.0	8	20	M5×0.8深8	5.5	9	16	9.3深8	13.5	19.5	M4
REC□UK25	15.5	18	32	50	10	10	10	22	20	43.5	21.5	13	33	20	38	8	M8×1.25	10	28	M5×0.8深8	5.5	9	20	9.3深9	19	24.5	M5
REC□UK32	19.5	22	40	62	12	11	12	29	24	51.5	23	12.5	42	24	48	10	M10×1.25	12	32	M6×1.0深9	6.6	13.5	24	11深11.5	21	30.5	M5

双作用尺寸表

单作用(弹簧压回)尺寸表

型号	H	没有磁环						内置磁环型													
		S			Z			W	S'						Z'						
		5st	10st	15st	5st	10st	15st		5st	10st	15st	5st	10st	15st	5st	10st	15st				
REC□UK6-□D	18	33	51	2.5	33	51	REC□UK6-□S	18	38	43	48	56	61	66	2.5	38	43	48	56	61	66
REC□UK10-□D	21	36	57	1	36	57	REC□UK10-□S	21	41	46	56	62	67	77	1	41	46	56	62	67	77
REC□UK16-□D	26	30	56	0	40	66	REC□UK16-□S	26	35	40	50	61	66	76	0	45	50	60	71	76	86
REC□UK20-□D	29	36	65	1	46	75	REC□UK20-□S	29	41	46	56	70	75	85	1	51	56	66	80	85	95
REC□UK25-□D	33	40	73	-1	50	83	REC□UK25-□S	33	45	50	60	78	83	93	-1	55	60	70	88	93	103
REC□UK32-□D	42	42	84	-4	52	94	REC□UK32-□S	42	47	52	62	89	94	104	-4	57	62	72	99	104	114

单作用(弹簧压出)尺寸表

*St+行程

型号	H			φT	U	Y	没有磁环						内置磁环型								
	S						Z			W	S'						Z'				
	5st	10st	15st				5st	10st	15st		5st	10st	15st	5st	10st	15st					
REC□UK6-□T	23	28	33	6深4.8	10	10.5	38	43	48	61	71	81	2.5	38	43	48	61	71	81		
REC□UK10-□T	26	31	36	6深5	10.5	11.5	41	46	56	67	77	92	1	41	46	56	67	77	92		
REC□UK16-□T	31	36	41	7.6深6.5	12.5	15.5	45	50	60	76	86	101	0	45	50	60	76	86	101		
REC□UK20-□T	34	39	44	9.5深8	13.5	19.5	41	46	56	75	85	100	1	51	56	66	85	95	110		
REC□UK25-□T	38	43	48	9.5深9	19	24.5	45	50	60	83	93	108	-1	55	60	70	93	103	118		
REC□UK32-□T	47	52	57	11深11.5	21	30.5	47	52	62	94	104	119	-4	57	62	72	104	114	129		